

BW DWR - TOWER

Atomizzatore trainato con ventilatore contro-rotante opposto con torre
Trailed sprayer with opposite counter-rotating fan with tower
Atomiseur tracté avec ventilateur contra rotatif opposé avec tour

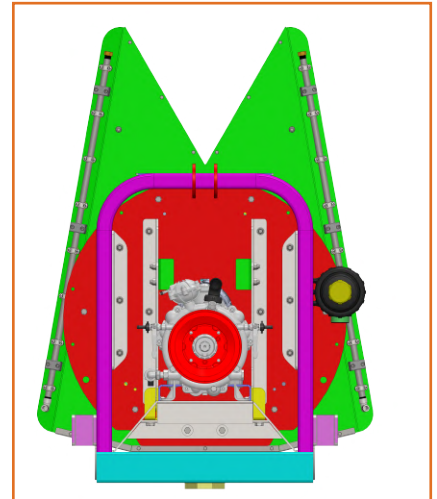
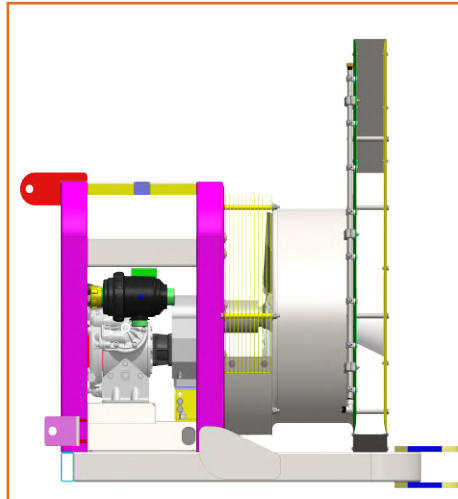
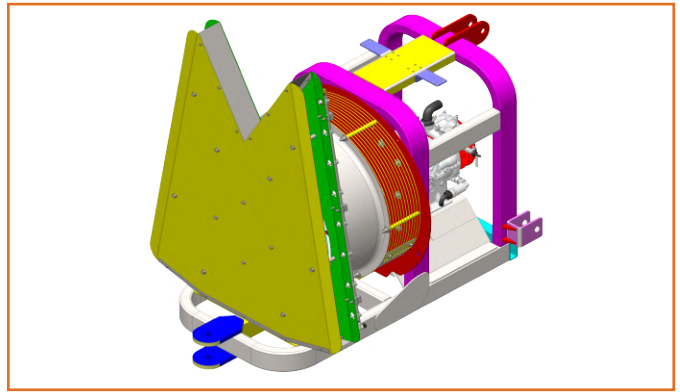
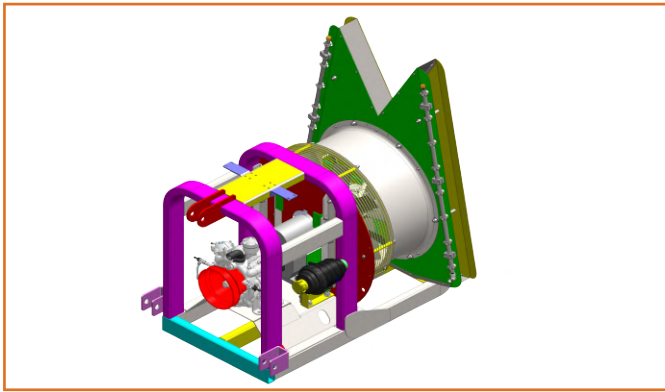

STANDARD EQUIPMENT

- Air mounted group with two counter rotating nylon fans at double speed
- Nozzle-Holder arches in stainless steel with n.16 Brass anti-drip double nozzles
- Reinforced Hot Galvanized Chassis
- Electric Remote Command Unit ARAG model GR881 from tractor with pressure regulator ECC
- Stainless Steel Counter-Rotating Fan Unit (Ø 700 DVR S-TOWER) with adjustable upper and lower deflector
- ANNOVI REVERBERI brass pump model BHS 105
- Connection pipes kit to the trailed Tank
- Back Trailer hitch with connection plug to the hook the sprayer, exhaust valves for the whole system to drain the water from the circuit
- Machine is supplied with drive shaft model T50/900
- In-line brass filter model M146

QUICK DIMENSION

